

pyrazines, pyridines, pyrimidines, and the purine, adenine.³⁰ While conceivably some of these products are synthesized in the pyrolysis step, there are reasons for thinking this is not a major effect.^{13,28} The subsequent chemistry of this material, episodically flooded with liquid water, and interacting with presumptive C₂H₆/CH₄/N₂ oceans, might lead to a rich and interesting organic chemistry.

When, in 1973-1974, tholins were first suggested for Titan, "gas chromatograph/mass spectrometer entry probes into the Titanian atmosphere" were urged.¹ Such instruments are currently included in the joint NASA/European Space Agency Cassini/Huygens mission and, some time after the turn of the millennium, might conceivably shed considerable light not just on Titan's organic chemistry but also on the early Earth's.

Future Work

Suggestions for extending the simulation and analytic work described above include

1. better simulations, including lower pressures, temperatures, and CH₄ mass fractions, with control of wall effects;
2. inclusion of 1-100 ppm amounts of CO, detected by recent millimeter wave observations;³⁶

(30) Khare, B. N.; Sagan, C.; Thompson, W. R.; Arakawa, E. T.; Suits, F.; Calcott, T. A.; Williams, M. W.; Shrader, S.; Ogino, H.; Willingham, T. O.; Nagy, B. *Adv. Space Res.* 1984, 4, 59-68.

(31) Coustenis, A.; Bézard, B.; Gautier, D. *Icarus* 1989, 80, 54-76.

(32) Coustenis, A. The Atmosphere of Titan from Voyager Infrared Observations. Doctoral Thesis, Univ. Paris VII, 1989; Chapter 5.

(33) Khare, B. N.; Sagan, C.; Arakawa, E. T.; Meisse, C.; Gilmour, I. *Proceedings of the First International Conference on Laboratory Research for Planetary Atmospheres* (NASA CP-3077); U.S. Government Printing Office: Washington, DC, 1990; pp 340-356.

(34) Khare, B. N.; Sagan, C.; Thompson, W. R. *J. Geophys. Res.* 1987, 92, 15067-15082.

(35) Khare, B. N.; Cheng, L.; Sagan, C.; Meisse, C.; Arakawa, E. T.; Matthews, C. N. *Bull. Am. Astron. Soc.* 1991, 23, 1186.

(36) Marten, A.; Gautier, D.; Tanguy, L.; Lecacheux, A.; Rosolen, C.; Paubert, G. *Icarus* 1988, 76, 558-562.

3. study of the dose and composition dependence of tholin optical constants;
4. simultaneous UV/electron irradiation experiments;
5. analysis of laboratory simulation products, both gases and aerosol solids, by Cassini/Huygens proof test instruments.

Jupiter

Similar work on both gas-phase organic products and tholins is underway for the experimentally more difficult atmosphere of Jupiter, where there is a roughly 1000:1 H₂/He dilution of NH₃/CH₄/H₂O, and in which the cloud structure and optical properties are complex and heterogeneous (e.g., refs 37 and 38). The multi-colored clouds of Jupiter may include tholins as important chromophores, but elemental sulfur, elemental phosphorus, and their compounds have also been suggested.³⁹ The first entry probe into the atmosphere of a Jovian planet is aboard the Galileo spacecraft, scheduled to encounter Jupiter in late 1995. The probe includes a mass spectrometer designed to return in situ data on atmospheric chemistry down almost to the predicted level of the deep aqueous ammonia clouds. While the high-gain antenna of the Galileo spacecraft is at the present writing stuck in an unusable position, all entry probe data can be returned by a low-gain antenna currently working to specifications.

The research described here was supported by NASA. We thank C. P. McKay and R. E. Samuelson for discussions on Figure 4 and our long-term collaborator on the determination of optical constants, E. T. Arakawa, as well as F. McLafferty and the referees.

(37) McDonald, G. D.; Khare, B. N.; Thompson, W. R.; Sagan, C. *Icarus* 1991, 94, 354-367.

(38) McDonald, G. D.; Thompson, W. R.; Sagan, C. *Bull. Am. Astron. Soc.* 1991, 23, 1136.

(39) West, R. A.; Strobel, D. F.; Tomasko, M. G. *Icarus* 1986, 65, 161-218.

Energy Flow from Excited Molecules on Salt Surfaces

GEORGE E. EWING

Department of Chemistry, Indiana University, Bloomington, Indiana 47405

Received January 2, 1992

Why Study Salt Surfaces?

Sodium chloride was one of the first crystal structures assigned by W. H. Bragg at the birth of X-ray crystallography.¹ The electric fields resulting from the charges of the ions together with a reasonable form for their repulsive interaction can account for the face-centered cubic structure of the crystal as well as for its

binding energy, as reviewed in Pauling's classic book.² Indeed, the ionic solid exhibits such ideal behavior that it is the favored example for introductory discussions of crystallography, phonon behavior, and thermodynamic properties in physical chemistry³ and physics⁴ texts. The surface of salt is also of historical interest. One of the early demonstrations of the wave properties of matter was from observations of helium diffraction

George Ewing graduated from Yale University in 1956 with a B.S. in chemistry. He learned to do research from George C. Pimentel at the University of California at Berkeley, where he received a Ph.D. in 1960. He has worked in a variety of areas of chemical physics, and this is his third article to be published in *Accounts of Chemical Research*. His current interests are studies of structure and dynamics on the surface of clusters and single crystals.

(1) Bragg, W. L. *R. Soc. London Proc.* 1913, 84A, 248.

(2) Pauling, L. *The Nature of the Chemical Bond*, 2nd ed.; Cornell University Press: Ithaca, NY, 1948.

(3) Atkins, P. W. *Physical Chemistry*, 4th ed.; W. H. Freeman: New York, 1990.

(4) Kittel, C. *Introduction to Solid State Physics*, 6th ed.; Wiley: New York, 1986.

from a cleaved face of NaCl by Estermann and Stern.⁵ The observed diffraction pattern from the NaCl(100) surface is consistent with the ion spacings of the bulk crystal. Over the years, modeling of the surface properties of salt has yielded deep understanding of the force fields surrounding the ions and the dynamics of their motions.⁶⁻⁸

In answer to the question beginning this Account, because the substrate of NaCl is probably better understood than most other solids, it seems natural to choose this system to explore surface processes not so well understood. A phenomenon we shall explore is the energy flow from vibrationally or electronically excited molecules on NaCl surfaces. The first time-domain measurements of vibrational relaxation from a monolayer on any well-defined surface were not published until 1990.⁹⁻¹² The energy flow from electronic excitation of adlayers also includes the possibility of photochemistry of the adsorbed molecules. Along the way we will need to consider the nature of the bonding of molecules to salt and the structure of the adlayer. Finally, we shall draw attention to the chemistry that occurs on the surfaces of the 10^9 – 10^{10} metric tons of salt particles that are thrown up into the atmosphere by the world's oceans each year.¹³

Although we shall concentrate on our own recent efforts with small molecules on NaCl(100), we have benefited enormously from others working in the field. The early pioneering work on NaCl and other alkali halide surfaces is described in de Boer's classic text.¹⁴ The alkali halide surfaces were rediscovered decades later by Kozirowski and Folman,¹⁵ who developed their potential for infrared spectroscopy. From time to time others, in particular Heidberg and Zehme,¹⁶ Smart and Sheppard,¹⁷ and Zecchina et al.,¹⁸ have used crystallites of alkali halides for spectroscopic and other chemical studies. Studies of photochemistry of molecules on single crystals of LiF(100), begun in the 1980s by Polanyi and his group,¹⁹ are continuing.²⁰ Infrared spectroscopy of CO and other small molecules on NaCl(100) single crystals, initiated in 1987 by ourselves²¹ and Heidberg and his associates,²² has pro-

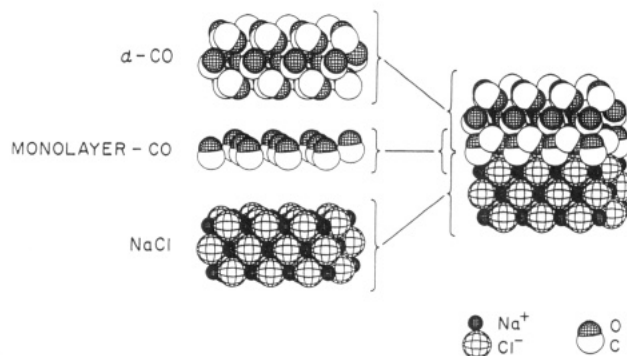

Figure 1. Structure of monolayer and multilayer CO on NaCl(100). Reprinted with permission from Chang, H.-C.; Ewing, G. E. *J. Electron Spectrosc. Relat. Phenom.* **1990**, *54/55*, 39. Copyright 1990 Elsevier.

ceeded on a parallel course.

In order to establish the background for our discussion of energy flow, we need to look closely at the surface of salt and the properties of some of its adlayers.

Salt Surfaces

Clean, flat surfaces of NaCl are easy to prepare. For physisorption and energy-transfer experiments, one starts with a single crystal cube available from any one of a variety of suppliers. A knife blade is aligned parallel to one of the faces, and a gentle tap with a hammer cleaves away the old surface. With practice, rectangular slabs with fresh, macroscopically smooth surfaces of desired dimensions can be prepared. The structure and ionic bonding within NaCl strongly favors production of (100) faces on cleaving. While these faces readily adsorb moisture from the air, no irreversible chemistry occurs, and on introduction into an ultrahigh vacuum (UHV) chamber and mild bakeout the water is pumped away.²³

Microscopic evaluation of the NaCl(100) face by transmission electron microscopy (TEM)^{24,25} and atomic force microscopy (AFM) measurements²⁶ reveals flat terraces extending for 100 nm or so which are then interrupted by steps of atomic dimensions. Terraces of this size can accommodate 10^4 – 10^5 molecules.²⁷

An idealized image of a portion of the (100) face at higher resolution is shown in Figure 1. The ionic radius of Cl^- of 181 pm is almost twice that of Na^+ at 95 pm.² Both helium diffraction measurements^{5,28} and AFM studies²⁶ are consistent with this idealized picture. Calculations, however, reveal subtle readjustments of the positions and electrical properties of the ions at the surface.⁷

The surfaces we have just discussed have exposed areas of typically $\sim 1 \text{ cm}^2$. Sublimation of salt slivers in a vacuum of 10^{-4} – 10^{-5} mbar produces cubic crystallites, each a tiny version of the bulk crystal.²⁹ These crystallites are deposited as a thin film transparent throughout the infrared and into the ultraviolet region. A film weighing 1 g may have a surface area on the

(5) Estermann, I.; Stern, O. *Z. Phys.* **1930**, *61*, 95.

(6) Lennard-Jones, J. E.; Dent, B. M. *Trans. Faraday Soc.* **1928**, *24*, 92.

(7) Yanagihara, T.; Yomogita, K. *Surf. Sci.* **1989**, *219*, 407.

(8) Safron, S. A.; Brug, W. P.; Chern, G.; Duan, J.; Skofronick, J. G.; Manson, J. R. *J. Vac. Sci. Technol.* **1990**, *A8*, 2627.

(9) Harris, A. L.; Rothberg, L.; Dubois, L. H.; Levinos, N. J.; Dhar, L. *Phys. Rev. Lett.* **1990**, *64*, 2086.

(10) Beckerle, J. D.; Casassa, M. P.; Cavanagh, R. R.; Heilweil, E. J.; Stephenson, J. C. *Phys. Rev. Lett.* **1990**, *64*, 2090.

(11) Guyot-Sionnest, P.; Dumas, P.; Chabal, Y. J.; Hagashi, G. S. *Phys. Rev. Lett.* **1990**, *64*, 2156.

(12) Chang, H.-C.; Ewing, G. E. *Phys. Rev. Lett.* **1990**, *65*, 2125.

(13) Blanchard, D. C.; Woodcock, A. H. *Ann. N.Y. Acad. Sci.* **1980**, *338*, 330.

(14) de Boer, J. H. *Electron Emission and Adsorption Phenomena*; University Press: Cambridge, 1935.

(15) Kozirowski, Y. A.; Folman, M. *J. Chem. Phys.* **1964**, *41*, 1509.

(16) Heidberg, J.; Zehme, S. *Ber. Bunsenges. Phys. Chem.* **1968**, *72*, 1870.

(17) Smart, R.; Shepard, N. *J. Chem. Soc., Faraday Trans. 2* **1976**, *72*, 707.

(18) Zecchina, A.; Scarano, D.; Garrone, E. *Surf. Sci.* **1985**, *160*, 492 previous work cited.

(19) Bourdon, E. B. D.; Cowin, J. P.; Harrison, I.; Polayni, J. C.; Stegner, J.; Stanners, C. D.; Young, P. A. *J. Phys. Chem.* **1984**, *88*, 6100.

(20) Bourdon, E. B. D.; Cho, C.-C.; Das, P.; Polayni, J. C.; Stanners, C. D.; Xu, G.-Q. *J. Chem. Phys.* **1991**, *95*, 1361.

(21) Richardson, H. H.; Ewing, G. E. *J. Phys. Chem.* **1987**, *91*, 5833.

(22) Heidberg, J.; Stahmer, K.-W.; Stein, H.; Weiss, H. *J. Electron Spectrosc. Relat. Phenom.* **1987**, *45*, 87.

(23) Estel, J.; Hoinkes, H.; Kaarmann, H.; Nahr, H.; Wilsch, H. *Surf. Sci.* **1976**, *54*, 393.

(24) Bassett, G. A. *Philos. Mag.* **1958**, 1042.

(25) Bethge, H. *Phys. Status Solidi* **1962**, *2*, 3.

(26) Meyer, G.; Amer, N. M. *Appl. Phys. Lett.* **1990**, *56*, 2100; *Appl. Phys. Lett.* **1990**, *57*, 2089.

(27) Disselkamp, R.; Chang, H.-C.; Ewing, G. E. *Surf. Sci.* **1990**, *240*, 193.

(28) Benedek, G.; Brusdeylins, G.; Doak, R.; Skofronick, J.; Toennies, P. *Phys. Rev.* **1983**, *28B*, 2104.

(29) Smart, R. *St. C. Trans. Faraday Soc.* **1971**, *67*, 1183.

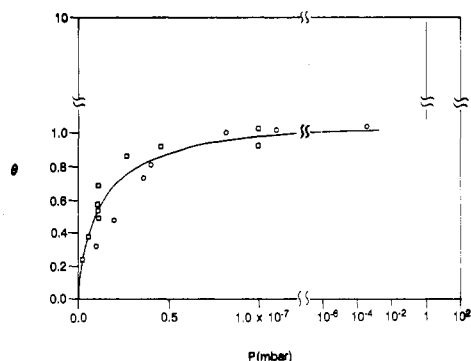

Figure 2. Isotherm for CO on NaCl(100) at 55 K. The squares are from XPS measurements and the circles from IR photometry of the sub-monolayer and monolayer. The curve for the region, $\theta \leq 1$, is the theoretical Langmuir isotherm. The vertical line is from vapor pressure measurements of α -CO. Note change to logarithmic scale beyond 10^{-7} mbar and $\theta = 1$. Reprinted with permission from Chang, H.-C.; Ewing, G. E. *J. Electron Spectrosc. Relat. Phenom.* 1990, 54/55, 39. Copyright 1990 Elsevier.

order of 100 m^2 .^{14,29,30} Such a large surface area opens up a variety of interesting experiments that we shall describe. A characteristic of these salt films is that the edge, corner, and defect sites of the crystallite cubes can become comparable to the sites available on the smooth (100) terraces.

An exceedingly important source of salt surfaces is the particulates ejected into the atmosphere by wave action from the world's oceans.^{31,32} Again, the crystallites appear to approximate the cubes of the bulk crystal.³³ The intricate surface chemistry at the surface of these crystallites is yet to be explored in detail.

Physisorption, Adlayer Structures, and Spectroscopy

A variety of small molecules form well-ordered adlayers on NaCl(100) surfaces. These molecules are held to the underlying surface by physisorption bonds with contributions from electrostatic, dispersion, induction, and repulsion terms.³⁴ The same catalogue of terms can also describe van der Waals molecular bonding.³⁵ However in the case of physisorption to an ionic surface, the electrostatic interactions are particularly important.

The proposed monolayer structure of CO on NaCl(100) in its high-temperature phase is given in Figure 1. The vertical CO alignment at the surface with the carbon end down over Na^+ is dictated by the quadrupole and octapole moments as they minimize their energy of interaction with the appropriate electric field gradients.³⁶ (Because of the small dipole of CO, this electrostatic interaction makes only a minor contribution to the surface bond.) With estimates of dispersion, induction, and repulsion terms, the calculated physisorption bond dissociation energy of $D_e = 17 \text{ kJ mol}^{-1}$, given by Gevitzman, Kozirowski, and Folman,³⁴ is comparable to that of $D_e = 20 \text{ kJ mol}^{-1}$ found from

(30) Richardson, H. H.; Baumann, C.; Ewing, G. E. *Surf. Sci.* 1987, 185, 15.

(31) Woodcock, A. H.; Kientzler, C. F.; Arons, A. B.; Blanchard, D. C. *Nature* 1953, 172, 1144.

(32) Knelman, F.; Dombrowski, N.; Newill, D. M. *Nature* 1954, 173, 261.

(33) Twomey, S. J. *Appl. Phys.* 1953, 24, 1099.

(34) Gevitzman, R.; Kozirowski, Y.; Folman, M. *Trans. Faraday Soc.* 1969, 65, 2206.

(35) Stone, A. J.; Price, S. L. *J. Phys. Chem.* 1938, 92, 3325.

(36) Gready, J. E.; Bacskey, G. B.; Hush, N. S. *Chem. Phys.* 1978, 31, 375.

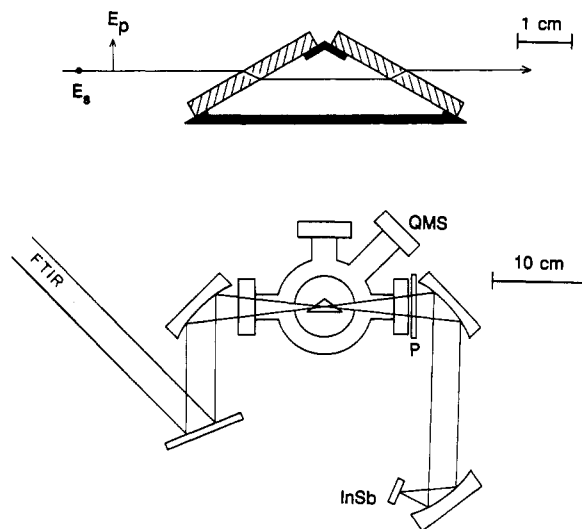

Figure 3. UHV chamber and optical schematic. The lower portion of the figure shows the chamber. Transfer optics carry radiation from the FTIR interferometer through two optical ports, a polarizer (P), and onto an InSb detector. These ports and the upper port are used for laser experiments. The fourth port goes to a quadrupole mass spectrometer (QMS). The upper portion of the figure shows an enlarged view of the salt crystals (cross-hatched) and their relationships to E_p and E_s polarized light. Four surfaces are available for adsorption. Reprinted with permission from Chang, H.-C.; Ewing, G. E. *J. Electron Spectrosc. Relat. Phenom.* 1990, 54/55, 39. Copyright 1990 Elsevier.

isotherm measurements.^{30,37,38}

We show such an isotherm in Figure 2 for CO adsorption at 55 K. The open circles and squares are from infrared (IR) absorption³⁹ and X-ray photoelectron spectroscopy (XPS)³⁷ measurements, respectively. The solid curve is a theoretical Langmuir isotherm. The reasonable fit of this data by the theoretical curve favors the Langmuir model in describing the adsorption process. This model assumes that adsorption to an unoccupied site on the surface (e.g., an Na^+ ion) is uninfluenced by the coverage of a neighboring site.³ Furthermore, the model considers that adsorption stops when all sites are covered. This saturation coverage is called $\theta = 1$. As the data of Figure 2 indicate, saturation is essentially complete at 10^{-7} mbar and 55 K. Increases in pressure by 6 orders of magnitude result in no significant further adsorption. Not until a pressure of 1 mbar is reached does adsorption resume. This is the vapor pressure of bulk crystalline CO at 55 K,⁴⁰ and here multilayers begin to form as indicated by the vertical rise in the isotherm.

Polarized IR spectroscopy by Richardson et al.²¹ and Heidberg et al.²² confirms the high-temperature CO on the NaCl(100) structure in Figure 1. An apparatus for making these Fourier transform infrared (FTIR) measurements is shown in Figure 3. Two slabs of NaCl with (100) faces exposed are mounted in a UHV chamber. The temperature of the salt crystals can be set to the desired value (e.g., 55 K), while the surrounding gas pressure can be adjusted to achieve saturation coverage. The interrogating light is polarized either E_p (electric field in the plane of Figure 3) or E_s (electric field per-

(37) Hardy, J. P.; Ewing, G. E.; Stables, R.; Simpson, C. J. S. M. *Surf. Sci.* 1985, 159, L474.

(38) Ewing, G. E. *Int. Rev. Phys. Chem.* 1991, 10, 391.

(39) Noda, C.; Ewing, G. E. *Surf. Sci.* 1990, 240, 181.

(40) Clayton, J. O.; Giaque, W. F. *J. Am. Chem. Soc.* 1932, 54, 2610.

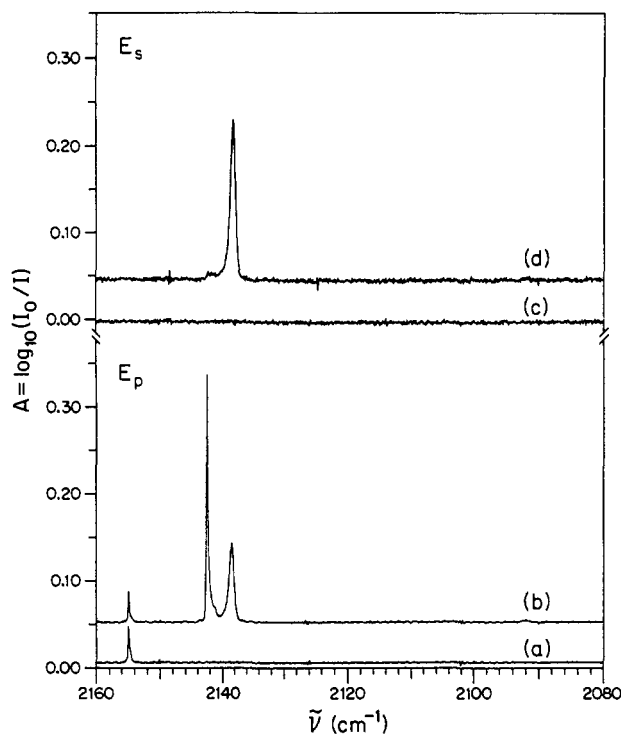

Figure 4. Infrared absorption on monolayer and multilayer CO on NaCl(100) at 22 K. Monolayer CO spectra are shown with E_p and E_s polarizations in spectra a and c, respectively. Multilayer absorption with E_p and E_s polarizations are shown in spectra b and d. Reprinted with permission from Chang, H.-C.; Richardson, H. H.; Ewing, G. E. *J. Chem. Phys.* 1988, 89, 7561. Copyright 1988 American Institute of Physics.

pendicular to the plane of the figure). With monolayer CO on NaCl(100), only E_p radiation is absorbed. There is no absorption by E_s polarized light. Monolayer spectra are shown as a and c in Figure 4. These polarization measurements are only consistent with the vertical arrangement of CO on NaCl(100), as shown in Figure 1. Also shown in Figure 4 as b and d is the absorption by multilayer CO. The features near 2140 cm^{-1} , found in bulk crystalline CO,⁴¹ are easy to distinguish from the monolayer absorption.

The simple structure of monolayer CO on NaCl(100) at 55 K with each CO aligned vertically on the surface, the high-temperature structure, undergoes a phase transition below about 30 K.^{42,43} Each CO is canted relative to a neighbor, and there are now two molecules per unit cell.

The structures of other adlayers, CO_2 ,⁴⁴⁻⁴⁶ C_2H_2 ,⁴⁷ CH_4 ,⁴⁸ and H_2O ,⁴⁹ on NaCl(100) have been deduced from IR measurements. A structure for HBr on LiF(100) has been proposed.⁵⁰ These spectroscopic studies

(41) See: Dubost, H.; Zumofen, G. *J. Chem. Phys.* 1978, 68, 3747.

(42) Schmicker, D.; Toennies, J. P.; Vollmer, R.; Weiss, H. *J. Chem. Phys.* 1991, 96, 9412.

(43) Heidberg, J.; Kampshoff, E.; Suhren, M. *J. Chem. Phys.* 1991, 95, 9408.

(44) Berg, O.; Ewing, G. E. *Surf. Sci.* 1989, 220, 207.

(45) Heidberg, J.; Kampshoff, E.; Kühnemuth, R.; Schönekas, O.; Stein, H.; Weiss, H. *Surf. Sci.* 1990, 226, L43; *Bunsenges. Phys. Chem.* 1990, 94, 112; *Ibid.* 1990, 94, 118; *Ibid.* 1990, 94, 124.

(46) Heidberg, J.; Kampshoff, E.; Kühnemuth, R.; Schönekas, O.; Stein, H.; Weiss, H. *Bunsenges. Phys. Chem.* 1990, 94, 112; *Ibid.* 1990, 94, 118; *Ibid.* 1990, 94, 124.

(47) Dunn, K.; Ewing, G. E. *J. Phys. Chem.*, in press.

(48) Quattrocci, L.; Ewing, G. E. *J. Chem. Phys.* 1992, 96, 4205.

(49) Heidberg, J.; Haser, W. *J. Electron Spectrosc. Relat. Phenom.* 1990, 54/55, 971.

(50) Blass, P. M.; Jackson, R. C.; Polanyi, J. C.; Weiss, H. *J. Electron Spectrosc. Relat. Phenom.* 1990, 54/55, 993.

are complemented by recent characterizations of the unit cells of adlayers on NaCl(100) by electron⁵² and helium diffraction^{42,51} methods.

Vibrational Flow

Suppose we vibrationally excite a CO molecule within the adsorbed monolayer on NaCl(100). What is the fate of this vibrational excitation? Let us consider some of the relaxation channels in the following equations:

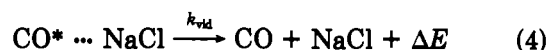
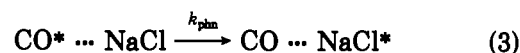
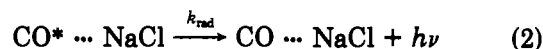
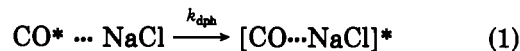

In eq 1, the phase of the vibration, initially localized in CO^* (the asterisk represents this excitation), is interrupted by motions against the surface bond (indicated by the dots). An experimental consequence of this relaxation, with rate k_{dph} , is a broadening of the vibrational band profile as the temperature of the system is raised. Radiation from CO^* in eq 2 proceeds with rate k_{rad} . In eq 3, the vibrational excitation in CO^* is transferred to the underlying substrate, and phonon excitation results at rate k_{phn} . Finally, since the vibrational energy of CO^* exceeds the physisorption bond strength, desorption is possible and CO, now vibrationally relaxed, flies away with kinetic energy ΔE . This process, at rate k_{vid} , is called vibrationally induced desorption as shown in eq 4. Processes 2–4 result in loss of population of the vibrational excited state of CO^* , while dephasing still maintains excitation in the vibrating chemical bond. In a series of experiments, we^{12,53-55} determined all of the rate constants for the processes in eqs 1–4.

We have observed that both the position of the infrared absorption and the bandwidth of CO on NaCl(100) change with temperature.⁵³ A quantitative analysis shows that these two spectroscopic changes follow the same exponential dependence on temperature. This behavior is consistent with a dephasing mechanism, as discussed first for organic liquids⁵⁶ and then for adsorbed molecules.^{57,58} For our system it is argued that thermal fluctuations arising from the excitation and de-excitation of motions of CO against the NaCl(100) surface bond interrupt the phase of the vibrating CO molecule to produce the observed broadening. If we ignore the coupling of vibrational motions among the CO molecules within the monolayer, we arrive at a dephasing rate of $k_{\text{dph}} \approx 10^{11} \text{ s}^{-1}$ near 55 K. This analysis is surely inadequate since vibrational motions of CO molecules within the monolayer are

(51) Lui, G.-Y.; Robinson, G. N.; Scoles, G.; Heiney, P. A. *Surf. Sci.* 1992, 262, 409.

(52) Schimmelpfennig, J.; Fölsch, S.; Henzler, M. *Surf. Sci.* 1991, 250, 198.

(53) Noda, C.; Richardson, H. H.; Ewing, G. E. *J. Chem. Phys.* 1990, 92, 2099.

(54) Chang, H.-C.; Ewing, G. E. *Chem. Phys.* 1989, 139, 55.

(55) Chang, H.-C.; Ewing, G. E. *J. Electron Spectrosc. Relat. Phenom.* 1990, 54/55, 39.

(56) Harris, C. B.; Shelby, R. M.; Cornelius, P. A. *Phys. Rev. Lett.* 1977, 38, 1415.

(57) Trenary, M.; Uram, K. H.; Bozso, F.; Yates, J. T., Jr. *Surf. Sci.* 1984, 146, 269.

(58) Persson, B. N. J.; Ryberg, R. *Phys. Rev. B* 1981, 24, 6954.

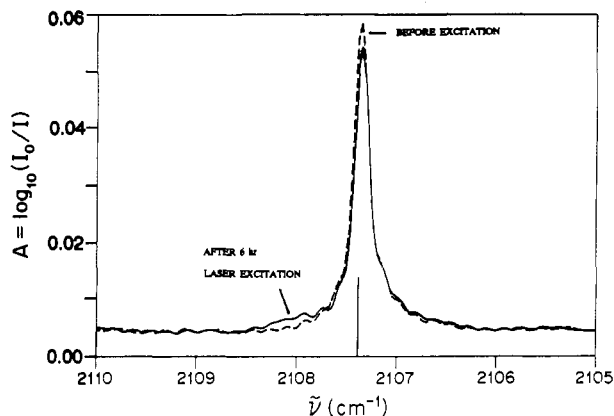

Figure 5. Infrared absorption of monolayer $^{13}\text{C}^{16}\text{O}$ on $\text{NaCl}(100)$ at 22 K. The transition, $\text{P}_{1-0}(9)$, from a gas-phase CO laser, used for excitation in the fluorescence and desorption experiments, is indicated by the vertical line. Reprinted with permission from Chang, H.-C.; Ewing, G. E. *Chem. Phys.* 1989, 139, 55. Copyright 1989 Elsevier.

coupled.^{27,59,60} Nevertheless, band broadening by about 0.2 cm^{-1} that we observe in the highest temperature spectra is consistent with a Heisenberg relaxation rate comparable to our estimate of k_{dph} . At low temperatures, below 10 K, surface motions of CO are effectively stilled and dephasing is quenched.

If there were neither photodesorption nor relaxation into the substrate, population loss of excited vibrational levels would be determined by radiation alone. Fluorescence decay would then follow the rate k_{rad} . However, as we shall soon see, the fluorescence decay is largely determined by k_{phn} . As Einstein showed many years ago,⁶¹ the radiative rate is simply related to the optical absorption properties of the system. We can obtain k_{rad} without time-domain measurements by using the integrated optical cross section, $\bar{\sigma}_z$, of CO on $\text{NaCl}(100)$. From an integrated absorbance measurement with monolayer data such as that given in Figure 4a, we obtain $\bar{\sigma}_z$. Using the Einstein relationship for this system⁵⁴

$$k_{\text{rad}}^{1 \rightarrow 0} = \pi c \bar{\nu}^2 \bar{\sigma}_z / 3 \quad (5)$$

with c the speed of light and $\bar{\nu}$ (cm^{-1}) the vibrational frequency, we determine $k_{\text{rad}}^{1 \rightarrow 0} = 11\text{ s}^{-1}$.⁵⁴ This calculated rate, appropriate for $\nu = 1 \rightarrow \nu = 0$ emission, is comparable to that of the isolated gas-phase molecule.⁶²

We can use the observed fluorescence decay rate k_{obsd} , as a clock to evaluate the rate constants k_{phn} and k_{vid} from

$$k_{\text{obsd}} = k_{\text{rad}} + k_{\text{phn}} + k_{\text{vid}} \quad (6)$$

This relationship states that the rate of vibrational population loss, k_{obsd} , is the sum of all channels, eqs 2–4, that result in dissipation of the excitation. As we shall show shortly, the vibrationally induced desorption rate, k_{vid} , is exceedingly small and can be neglected in the above equation. Chang and Ewing¹² made the fluorescence measurements by preparing a monolayer of CO on $\text{NaCl}(100)$ at 22 K (the low-temperature phase^{42,43}) and exciting the system with a laser. The

(59) Hammaker, R. M.; Francis, S. A.; Eischens, R. P. *Spectrochim. Acta* 1965, 21, 1295.

(60) Mahan, G. D.; Lucas, A. A. *J. Chem. Phys.* 1978, 68, 1344.

(61) See, for example: Pauling, L.; Wilson, E. B., Jr. *Introduction to Quantum Mechanics*; McGraw-Hill Book Co.: New York, 1935.

(62) Millikan, R. C. *J. Chem. Phys.* 1963, 38, 2855.

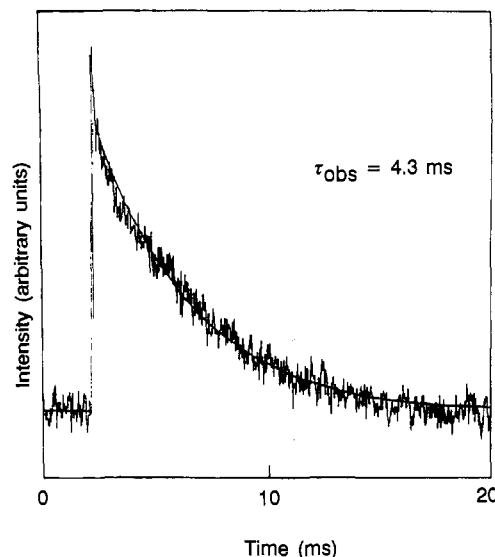
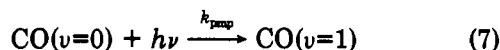

Figure 6. Time evolution of infrared fluorescence from a monolayer of vibrationally excited $^{13}\text{C}^{16}\text{O}$ on $\text{NaCl}(100)$. The fluorescence decay can be fitted with a simple exponential function (solid curve) and has a time constant of 4.3 ms. Reprinted with permission from Chang, H.-C.; Ewing, G. E. *Phys. Rev. Lett.* 1990, 65, 2125. Copyright 1990 American Institute of Physics.

laser pulses were introduced into the upper part of the UHV chamber of Figure 3, and the match of monolayer absorption with the laser emission (the vertical line) is shown in Figure 5. (In order to optimize the overlap of the adsorption profile with the laser output, the $^{13}\text{C}^{16}\text{O}$ isotope was excited.) Fluorescence was captured in the first overtone ($\Delta\nu = -2$) region by a cooled InSb detector following excitation from pulses of the Q-switched laser. The average of signals from 50 000 pulses gave the fluorescence decay shown in Figure 6 with a time constant of 4.3 ms or $k_{\text{obsd}} = 2.3 \times 10^2\text{ s}^{-1}$.

It would appear that, since k_{rad} is established, it remains only to do the simple extraction from eq 6 to obtain k_{phn} . However, we need to look more closely at the nature of the fluorescence experiment. In particular, we must account for the observation of fluorescence in the overtone region, e.g., $\nu = 2 \rightarrow \nu = 0$, as only the $\nu = 1$ level was pumped by the laser. Excitation of the CO $\nu = 1$ vibrational level proceeds according to



with rate constant k_{pmp} which depends on the cross section σ_z at the frequency of the pumping laser and its fluency.⁵⁴ This process is followed by energy pooling:

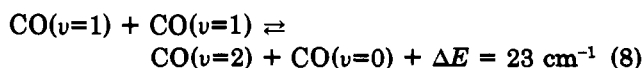

The reaction is exothermic by 23 cm^{-1} due to the anharmonicity of CO. This energy pooling process can continue to high vibrational states. (Pooling up to $\nu = 30$ has been observed for multilayer CO on $\text{NaCl}(100)$.⁶³ The use of filters in the monolayer fluorescence measurements suggests excitation to about the $\nu = 15$ level. From other studies of spontaneous emission of excited CO levels, it is known that the rate increases by a factor of 10 from $\nu = 1$ to $\nu = 15$.⁶³ Chang and Ewing therefore scaled their measured radiation rate, $k_{\text{rad}}^{1 \rightarrow 0} = 11\text{ s}^{-1}$, by

(63) Chang, H.-C.; Ewing, G. E. *J. Phys. Chem.* 1990, 94, 7635.

the geometric mean of this factor, $10^{1/2}$, to obtain an effective radiative rate of $k_{\text{rad}} \approx 30 \text{ s}^{-1}$. Taking $k_{\text{obsd}} \approx k_{\text{rad}} + k_{\text{phn}}$ by neglecting the k_{vid} term in eq 6, they therefore uncovered $k_{\text{phn}} \approx 2 \times 10^2 \text{ s}^{-1}$ as an effective phonon relaxation rate for levels $1 \leq \nu \leq 15$.

The value of k_{phn} just determined is in agreement with the classical model developed by Chance, Prock, and Silbey (CPS).⁶⁴ Here an oscillating point dipole (e.g., CO*) located at a distance z_e from the surface transmits its radiation at rate k_{rad} . The ability of the substrate (e.g., NaCl), the receiver, to accept this radiation depends on the value of its complex dielectric constant. The dielectric constant at the frequency of the radiation, $\bar{\nu}$, is defined by $\hat{\epsilon}(\bar{\nu}) = (\eta + i\kappa)^2$, where η is the index of refraction and κ the extinction coefficient. This simple model allows easy calculation of the relaxation to substrate phonons:

$$k_{\text{phn}} = \frac{3\eta\kappa k_{\text{rad}}}{16\pi\bar{\nu}^3|\hat{\epsilon}(\bar{\nu}) + 1|^2 z_e^3} \quad (9)$$

As we just determined, the effective radiative rate for $1 \leq \nu \leq 15$ is $k_{\text{rad}} \approx 30 \text{ s}^{-1}$. The geometric mean of the CO fundamental frequency in the range $\nu = 1$ to $\nu = 15$ is $\bar{\nu} \approx 1930 \text{ cm}^{-1}$, and $z_e = 3 \times 10^{-8} \text{ cm}$ is the distance between the CO center of mass and the center of an Na⁺ ion at the surface.⁵⁴ From the bulk optical properties of NaCl, $\eta = 1.52$ and $\kappa = 1.8 \times 10^{-9}$,⁶⁵ and the result of the calculation is $k_{\text{phn}} \approx 1.8 \times 10^2 \text{ s}^{-1}$, which is in remarkable (possibly fortuitous) agreement with the measured value of $2 \times 10^2 \text{ s}^{-1}$.

The reluctance of the NaCl phonons to accept energy from vibrating CO is consistent with the large energy mismatch. At the NaCl transverse optical mode of 164 cm^{-1} ,⁴ 12 phonons need to be excited to accommodate the CO vibrational energy of $\bar{\nu} \approx 1930 \text{ cm}^{-1}$. The channel of eq 3 is then expected to be an exceedingly inefficient relaxation process, as we find. By contrast, measurements of k_{phn} for vibrationally excited adlayers on semiconductor¹¹ or metal^{9,10} substrates can be faster by 7–10 orders of magnitude.

Guan et al.⁶⁶ have explored CO* on NaCl(100) in several models to examine the flow of vibrational energy. Unfortunately they use, as they admit, unrealistic parameters to describe the adsorbate surface interaction. As a consequence, their estimate of k_{phn} is many orders of magnitude larger than either the experimental value of the fluorescence measurement or the theoretical value from the CPS model.

The last relaxation channel to explore is the one that can lead to photodesorption. A previous measurement of laser-induced desorption of CO from NaCl film has been reported.⁶⁷ However, it has been argued that this may be a case of desorption following heating of the crystallites making up the film.⁵⁴ For the experimental measurement of this process for CO on single-crystal NaCl(100), again in its low-temperature phase, Chang and Ewing⁵⁴ chose a cw laser source. The focusing optics for the laser beam directed it along the same path as the interrogating FTIR radiation shown in Figure 3,

while a beam block (not shown) protected the InSb detector. An area of 0.1 cm^2 was bathed by either the laser or the FTIR radiation interrogating the monolayer before and after excitation. Use of geometric factors dictated by the optics and the cross section of the monolayer at the laser frequency together with the laser source power yielded a pumping rate of $k_{\text{pmp}} = 10 \text{ s}^{-1}$ (see eq 7) from the $\nu = 0$ to the $\nu = 1$ level. The low power of the laser, and relaxation to the substrate at rate k_{phn} , prevented saturation of the $\nu = 1$ level. Thus neither stimulated emission from the $\nu = 1$ level nor up-pumping to higher levels (e.g., eq 8) is important. The experiment involved measuring the integrated absorbance change of the monolayer before excitation by the laser and after an excitation time of 6 h. The absorbance change, the difference between the solid and dashed curves of Figure 5, was negligible. Nevertheless, an upper limit for the desorption rate, $k_{\text{vid}} \leq 10^{-4} \text{ s}^{-1}$, was provided by the possible error in the absorbance measurement.

Why is this vibrationally induced desorption rate so small, and what are the factors that govern the rate k_{vid} ? We can answer these questions by reviewing some simple propensity rules we have developed.^{54,68,69} We write

$$k_{\text{vid}} \approx 10^{13} \exp[-\pi(\Delta n_{\nu} + \Delta n_{\tau} + \Delta n_t + \Delta n_p)] \quad (10)$$

where 10^{13} s^{-1} gives the magnitude of the translational frequency of the adsorbed molecule (e.g., CO) against the substrate (e.g., NaCl). The argument of the exponent gives the total change in the quantum numbers during the relaxation process. This equation states that the lifetime of the excited state, through this relaxation channel, depends exponentially on the total quantum change for the process. Equation 10 is then consistent with selection rules familiar to spectroscopists that require small changes in quantum numbers if the transition is to have high probability. While values of k_{vid} resulting from the rate expression of eq 10 are quantitatively unreliable, the qualitative predictions provide understanding of both the experimental results and involved theoretical calculations.

The individual quantum number changes in the exponential of eq 10 are $\Delta n_{\nu} \approx |\Delta \nu|$ for the change in vibrational state of the excited molecule during the relaxation process. For the relaxation of eq 4, i.e., CO($\nu=1$) \rightarrow NaCl(100), where CO($\nu=1$) desorbs to give CO($\nu=0$), we have $\Delta n_{\nu} \approx |\Delta \nu = -1| = 1$. The change in rotational state is given by Δn_{τ} . If $\Delta n_{\tau} \approx 0$, the product of desorption leaves the surface rotationally cold. The number of phonons within the substrate that are excited by the desorption process is roughly given by Δn_p . Usually the biggest contribution to the total quantum number change is determined by the translational quantum number change:

$$\Delta n_t \approx (2m\Delta E)^{1/2}/2a\hbar \quad (11)$$

Equation 11 essentially counts the number of nodes of the plane wave describing the relaxed molecule of mass m near the surface as it leaves with kinetic energy ΔE . A Morse function is used to model the physisorption bond and is characterized by a range parameter a .

For CO on NaCl(100), the energy gap is the difference between the vibrational energy of CO and that needed

(64) Chance, R. R.; Prock, A.; Silbey, R. *Adv. Chem. Phys.* 1978, 37, 1.

(65) Palik, E. D., Ed. *Handbook of Optical Constants of Solids*; Academic Press: New York, 1985.

(66) Guan, Y.; Muckerman, J. T.; Uzer, T. *J. Chem. Phys.* 1990, 93, 4383, 4400.

(67) Heidberg, J.; Stein, H.; Weiss, H. *Surf. Sci.* 1987, 184, L431–L438.

(68) Ewing, G. E. *J. Phys. Chem.* 1987, 91, 4662.

(69) Lucas, D.; Ewing, G. E. *Chem. Phys.* 1981, 58, 385.

to break the surface bond, $\Delta E = \bar{\nu} - D_0 \approx 800 \text{ cm}^{-1}$. The range parameter is unfortunately difficult to estimate, and a typical value is $a \approx 2 \times 10^8 \text{ cm}^{-1}$.^{54,68,69} For a generous uncertainty, we assume a range from 1.5×10^8 to $3.0 \times 10^8 \text{ cm}^{-1}$, which gives $\Delta n_t \approx 6 - 12$. With $\Delta n_v \approx 1$, $\Delta n_r \approx 0$, and $\Delta n_p \approx 0$, we arrive at $k_{\text{vid}} \approx 10^{-5} - 10^{-3} \text{ s}^{-1}$. This estimate, while exceedingly approximate, does encompass the experimental rate of $k_{\text{vid}} \leq 10^{-4} \text{ s}^{-1}$ that we have determined.

To return to the question, why is k_{vid} so small for $\text{CO}(v=1) \cdots \text{NaCl}(100)$, the answer is because the change in total quantum numbers for the process is so large. Other theoretical considerations have not found k_{vid} to be small for this system. Ben Ephram et al.⁷⁰ suggest an important role for rotations in the photodesorption process. However, this rotation-assisted channel is likely closed in the monolayer of coupled CO. Their estimate of k_{vid} differs by 15 orders of magnitude from our measurement. Muckerman et al.,⁷¹ who we believe used an unrealistic value of a , calculated k_{vid} to be on the order of 10^{12} s^{-1} . Gortel et al.⁷² address the importance of Δn_p in their discussion of phonon-assisted desorption. Their estimate for k_{vid} , assuming similar values of the a parameter, is essentially in agreement with our result.

We have measured rates for all of the relaxation channels of CO^* on $\text{NaCl}(100)$. Since we have also provided theoretical models that can account, at least qualitatively, for these rates, we can use these models to make predictions of other systems.

In photometric studies of several adlayer systems,^{44,48,73} we have found that the integrated cross sections are near the values of the gas-phase molecules. Some of the discrepancy can be accounted for by considering the polarizability of the adlayer⁷³ and the electric field of the surface ions.⁷⁴ Our experience thus leads us to the conclusion that other small molecules on alkali halide surfaces will have radiative rates k_{rad} (calculated by relationships similar to eq 5) comparable to those of the gas-phase molecules.

The success of the CPS model in explaining k_{phn} for CO^* on $\text{NaCl}(100)$ leads us to expect that it may explain other systems as well. We have plotted $k_{\text{phn}}/k_{\text{rad}}$ from eq 9 in Figure 7 for the NaCl substrate with the adsorbate at $z_e = 3 \times 10^{-8} \text{ cm}$ over a region that extends from the far infrared to the vacuum ultraviolet. High-purity NaCl is assumed with optical constants taken from Palik.⁶⁵ The open circle is the datum for our study of CO^* on $\text{NaCl}(100)$. We see that k_{phn} is less than k_{rad} from the near infrared ($\sim 3000 \text{ cm}^{-1}$) into the ultraviolet ($\sim 60\,000 \text{ cm}^{-1}$). The relative rate for k_{phn} only begins to dominate at the edges of the spectral range (the mid to far infrared and the vacuum ultraviolet) where NaCl begins to absorb, as indicated by sizeable values of κ . According to the CSP model, NaCl acts as an inert substrate to adsorbed molecules excited in the region $60\,000 \text{ cm}^{-1} > \bar{\nu} > 3000 \text{ cm}^{-1}$. Thus adlayer fluorescence in the UV, visible, and infrared regions should be a common phenomenon with the NaCl sub-

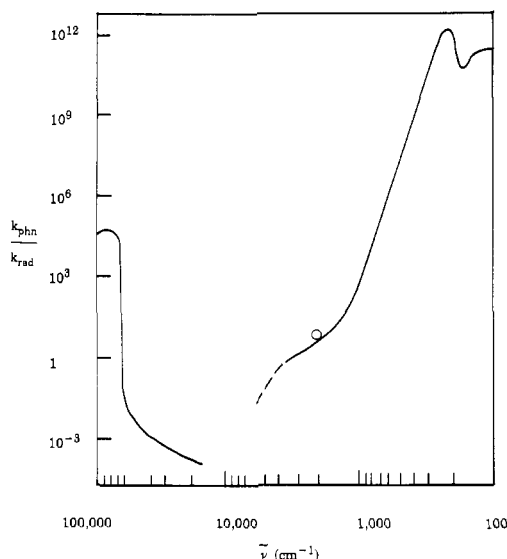

Figure 7. Phonon relaxation rates of excited molecules on NaCl. The curve is from the theoretical model of Chance, Prock, and Silbey⁶⁴ using dielectric constants from Palik.⁶⁵ The transition frequency of the molecule is $\bar{\nu}$, and it is 3 Å from the surface. The circle is from the vibrational relaxation study of $\text{CO}^* \cdots \text{NaCl}(100)$ described in the text.

strate. For other alkali halides and dielectric substrates, the energy transfer will become more or less likely depending on the values of η and κ . We note, however, that trace impurities in these substrates can introduce color centers¹⁴ and dramatically increase values of κ ⁷⁵ and, consequently, the energy-transfer rates.

There may well be other phonon excitation mechanisms beyond oscillating dipole transfer to the absorbing substrate as envisioned by the CPS model. A stronger coupling between the excited adlayer and its substrate may lead to much larger values of k_{phn} .

The selection rules implied by eqs 10 and 11 suggest that light adsorbates (small m) with a low vibrational desorption energy gap (small ΔE) will yield a higher k_{vid} rate. While there are many examples of desorption in response to surface heating following resonant vibrational absorption, no experiment has yet demonstrated a direct vibrational desorption channel. However there are several suggested systems for observing the effect.^{55,69}

Other Energy Flow Channels

We have explored several photochemical processes from electronically excited molecules adsorbed on NaCl crystallites:

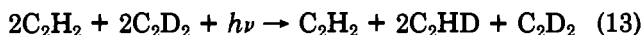
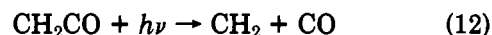

In cases where the excitation is the 185-nm ($54\,069 \text{ cm}^{-1}$) line from a low-pressure Hg lamp, photochemistry occurs for eqs 12 and 13 but not 14. We know from Figure 7 that this excitation would not be transferred effectively into the high-purity substrate. However, impurities commonly found in NaCl may indeed be responsible for substrate absorption and energy-transfer processes through an increase in κ near 185 nm.⁷⁵ Photochemistry of ketene in the gas phase⁷⁶ occurs by

(70) Ben Ephram, A.; Folman, M.; Heidberg, J.; Moiseyev, N. *J. Chem. Phys.* 1988, 89, 3840.

(71) Muckerman, J. T.; Uzer, T. *J. Chem. Phys.* 1989, 90, 1968.

(72) Gortel, Z. W.; Piercy, P.; Teshima, R.; Kreuzer, H. *J. Phys. Rev. B* 1987, 36, 3059.

(73) Richardson, H. H.; Chang, H.-C.; Noda, C.; Ewing, G. E. *Surf. Sci.* 1989, 216, 43.

(74) Lambert, D. K. *J. Chem. Phys.* 1991, 94, 133.

(75) Smakula, A. *Opt. Acta* 1962, 9, 205.

the primary step of eq 12. For the adsorbed phase, the secondary product C_2H_4 along with CO is observed.⁷⁷ Acetylene photochemistry by 185 nm produces the radicals H^\cdot and C_2H^\cdot in the gas phase and a number of secondary products.⁷⁶ The adsorbed-phase reaction 13 is by contrast remarkably clean, with hydrogen exchange among isotopomers the only evidence for chemistry.⁷⁸ Finally, 185-nm gas-phase photochemistry of SO_2 produces SO and O and secondary reactions generate SO_3 .⁷⁶ However no reaction for this system occurs in the adsorbed phase.⁷⁹ It is likely that the arrangements of the excited adsorbed species play a crucial role in the resulting photochemistry.¹⁹ While the mechanisms of adsorbed-phase photochemistry on dielectric substrates have been explored for LiF(100),^{19,20} we view the understanding of simple adsorbed-phase reactions like those in eqs 12-14 to be essentially lacking.

Finally, we turn our attention to the most poorly understood (but likely most important) energy pro-

cesses at salt surfaces. Here the surfaces are on particulates thrown into the atmosphere by the world's oceans. The salt particulates are freed of halides by reaction with sulfur and nitrogen oxides from anthropogenic and natural sources.⁸⁰⁻⁸² While these chemical exchange processes have been reproduced in the laboratory for gas-phase reactions with both liquid⁸² and solid surfaces,⁸³ the mechanisms for the reactions have not been established. We believe the spectroscopic techniques described in this Account may help elucidate these mechanisms.

We gratefully acknowledge the thoughtful research of members and former members of our group at Indiana University who have provided much of the science for this Account. We thank the National Science Foundation (CHE88-14717) and the donors of the Petroleum Research Fund, administered by the American Chemical Society, for their financial support.

Registry No. NaCl, 7647-14-5.

(80) Hitchcock, D. R.; Spiller, L. L.; Wilson, W. E. *Atmos. Environ.* 1980, 14, 165.

(81) Junge, C. E. *Tellus* 1956, 8, 127.

(82) Robbins, R.; Cadle, R.; Eckhardt, D. J. *Meteorol.* 1959, 16, 53.
Cadle, R.; Robbins, R. *Discuss. Faraday Soc.* 1960, 30, 155.

(83) Finlayson-Pitts, B. J.; Livingston, F.; Beako, H. *Nature* 1990, 343, 622.

(76) Okabe, H. *Photochemistry of Small Molecules*; Wiley: New York, 1978.

(77) Berg, O.; Ewing, G. E. *J. Phys. Chem.* 1991, 95, 2908.

(78) Dunn, K. Private communication.

(79) Berg, O. Private communication.

Photochemical and Photophysical Studies of Organic Molecules Included within Zeolites[†]

V. RAMAMURTHY,* D. F. EATON, and J. V. CASPAR

Central Research and Development, Experimental Station, The Du Pont Company, Wilmington, Delaware 19880-0328

Received February 10, 1992

Introduction

Being inspired by and having realized the complexity of natural systems, chemists have utilized a number of organized/confined media to study the photochemical and photophysical behavior of guest molecules. Examples of organized media in which the guest molecules' behavior has been investigated include molecular

crystals, inclusion complexes (both in the solid and solution states), liquid crystals, micelles and related assemblies, monolayers, LB films, surfaces, and more recently natural systems such as DNA.¹ The studies carried out thus far come under the following categories: (a) influence of media on the photochemistry and photophysics of molecules; (b) photochemistry and photophysics as a tool to understand the media; (c) influence of photochemistry and photophysics on the media; and (d) studies directed toward applications—devices, solar energy, biological implications. In this Account an overview of the activities in our laboratory,

V. Ramamurthy, after obtaining training in photochemistry under the direction of R. S. H. Liu (University of Hawaii, Ph.D., 1974), P. de Mayo (University of Western Ontario, postdoctoral research, 1974-1975), and N. J. Turro (Columbia University, postdoctoral research, 1975-1978), joined the faculty of the Department of Organic Chemistry, Indian Institute of Science, Bangalore, India, where he remained until 1987. In 1987 he joined Du Pont Central Research and Development, Wilmington, DE, as a member of the research staff where he continues his interest in the area of organic photochemistry.

David F. Eaton is Research Manager, Materials Science, within Du Pont Central Research and Development with responsibility for research programs in photochemistry, organic and inorganic nonlinear optics, and thin film physics. His education was obtained at Wesleyan University (A.B., 1968) and Caltech (Ph.D., Organic Chemistry, 1972). He has worked in several areas of photochemistry and photomaging during his career with Du Pont.

J. V. Caspar received his B.S. (1978) degree from the Massachusetts Institute of Technology. After completing his Ph.D. (1982) at the University of North Carolina at Chapel Hill under the direction of T. J. Meyer, he spent a year as a Postdoctoral Fellow with H. B. Gray at the California Institute of Technology. He joined the Central Research and Development Department at DuPont as a member of the research staff in 1983. His interests continue to revolve around diverse areas of photochemistry, photophysics, and spectroscopy.

[†] Contribution No. 6177.

(1) Fox, M. A., Ed. *Organic Phototransformation in Non-homogeneous Media*; American Chemical Society: Washington, D.C., 1985. Thomas, J. K. *Chemistry of Excitation at the Interfaces*; American Chemical Society: Washington, D.C., 1984. Ramamurthy, V., Scheffer, J. R., Turro, N. J., Eds. *Organic Chemistry in Anisotropic Media*. Tetrahedron Symposia in Print 29. *Tetrahedron* 1987, 43, 1197-1746. Kalyanasundaram, K. *Photochemistry in Microheterogeneous Systems*; Academic Press: New York, 1987. Matsuura, T., Anpo, M., Eds. *Photochemistry on Solid Surfaces*; Elsevier: Amsterdam, 1989. Balzani, V.; Scandola, F. *Supramolecular Photochemistry*; Ellis Horwood: New York, 1991. Schneider, H. J., Durr, H., Eds. *Frontiers in Supramolecular Organic Chemistry and Photochemistry*; VCH: Weinheim, 1991. Honda, K., Ed. *Photochemical Processes in Organized Molecular Systems*; North-Holland: Amsterdam, 1991. Ramamurthy, V., Ed. *Photochemistry in Organized and Constrained Media*; VCH: New York, 1991.